

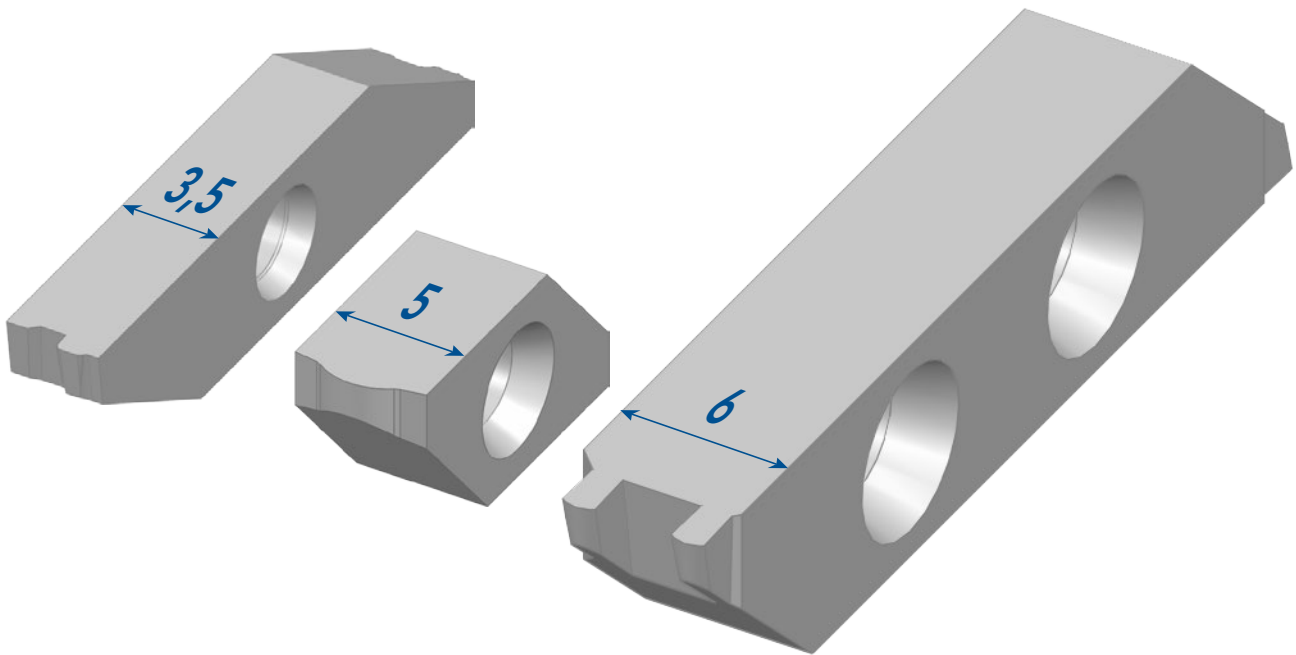



Grooving inserts Einstechplatten Plaquettes de fonçage





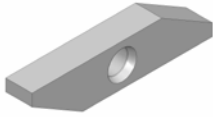
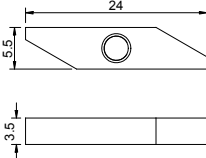

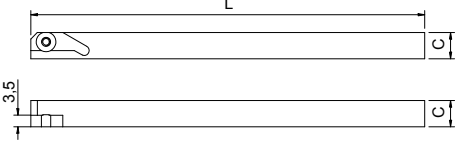
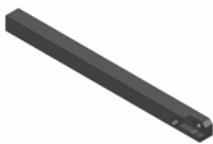
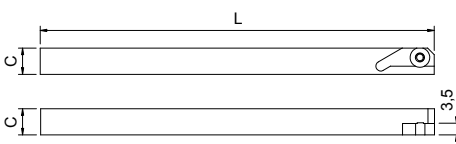



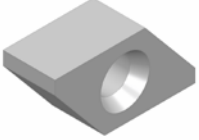
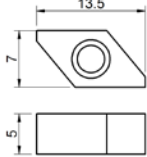

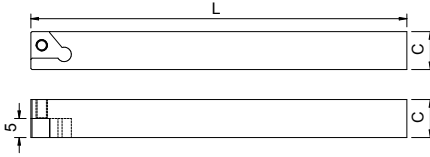

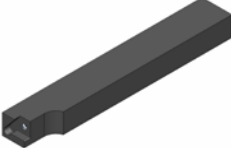
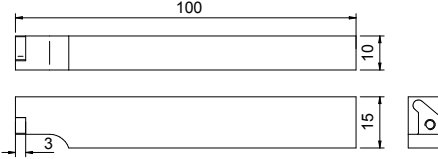
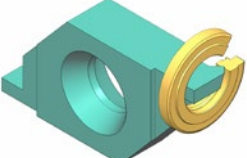
- Fully ground to your specification (examples of profiles illustrated).
- 3 different widths of blank inserts available.
- Double ended.
- Coated inserts.

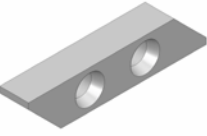
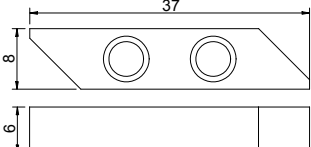
- Realisierung nach kundenspezifischen Angaben.
(Bilder : Realisierbare Profilbeispiele)
- 3 verschiedene Breiten der Wendepplattenrohlinge verfügbar.
- 2 Schneidkanten.
- Beschichtete Wendepplatte.

- Réalisation de profils personnalisés (ci-dessus : exemples de profils réalisables).
- Différentes largeurs d'ébauches disponibles.
- 2 arêtes de coupe.
- Plaquette revêtue.

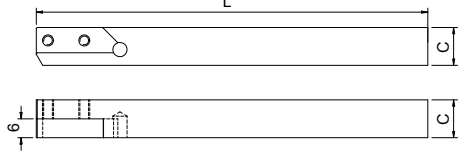
040R/L3,5K10 3,5 mm	Blank insert 3,5 mm (left and right) Rohling 3,5 mm (links und rechts) Plaquette ébauche 3,5 mm (gauche et droite)	Article nr. Artikel Nr. N° Article		
		040R/L3,5K10		
0xxR	Right tool-holder for 3,5 mm inserts Werkzeughalter rechts für 3,5 mm Wendeplatten Porte-outil à droite pour plaquettes 3,5 mm	Section C Querschnitt C Section C	Length L Länge L Longueur L	Article nr. Artikel Nr. N° Article
		7 x 7 8 x 8 10 x 10 12 x 12 16 x 16 20 x 20	124 124 124 124 100 100	007R 008R 010R 012R 016R 020R
0xxL	Left tool-holder for 3,5 mm inserts Werkzeughalter links für 3,5 mm Wendeplatten Porte-outil à gauche pour plaquettes 3,5 mm	Section C Querschnitt C Section C	Length L Länge L Longueur L	Article nr. Artikel Nr. N° Article
		7 x 7 8 x 8 10 x 10 12 x 12 16 x 16 20 x 20	140 140 124 124 100 100	007L 008L 010L 012L 016L 020L
001-2	Screw for tool-holders 0xxR and 0xxL Schraube für Werkzeughalter 0xxR und 0xxL Vis pour porte-outils 0xxR et 0xxL	Article nr. Artikel Nr. N° Article		
	M2,5 x 7,5	001-2		

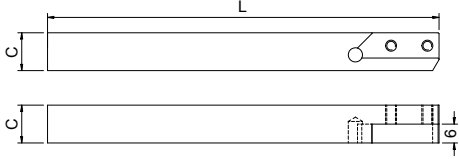
340R5 5 mm	Blank insert 5 mm (left and right) Rohling 5 mm (links und rechts) Plaquette ébauche 5 mm (gauche et droite)	Article nr. Artikel Nr. N° Article		
		340R5		
38xxR	Right tool-holder for 5 mm inserts Werkzeughalter rechts für 5 mm Wendeplatten Porte-outil à droite pour plaquettes 5 mm	Section C Querschnitt C Section C	Length L Länge L Longueur L	Article nr. Artikel Nr. N° Article
		10 x 10	99	3810R
		12 x 12	99	3812R
		16 x 16	99	3816R
100-3	Screw for tool-holder 38xxR Schraube für Werkzeughalter 38xxR Vis pour porte-outil 38xxR	Article nr. Artikel Nr. N° Article		
	M3,0 x 10	100-3		
3xx15RF	Frontal tool-holder for 3 mm inserts Frontalwerkzeughalter für 3 mm Wendeplatten Porte-outil frontal pour plaquettes 3 mm	Section C x D Querschnitt C x D Section C x D	Length L Länge L Longueur L	Article nr. Artikel Nr. N° Article
		10 x 15	99	31015RF
		12 x 15	99	31215RF
		<p>Please contact us for further information about 3 mm inserts. Bitte kontaktieren Sie uns für weitere Informationen zu 3 mm Wendeplatten. Veuillez nous contacter pour plus d'informations sur les plaquettes de 3 mm.</p>		
001-3	Screw for tool-holder 3xx15RF Schraube für Werkzeughalter 3xx15RF Vis pour porte-outil 3xx15RF	Article nr. Artikel Nr. N° Article		
	M3,0 x 6,5	001-3		
715R/L-6 6 mm	Blank insert 6 mm (left and right) Rohling 6 mm (links und rechts) Plaquette ébauche 6 mm (gauche et droite)	Article nr. Artikel Nr. N° Article		
		715R/L-6		

100BH3-1xxR-6 	Right tool-holder for 6 mm inserts Werkzeughalter rechts für 6 mm Wendeplatten Porte-outil à droite pour plaquettes 6 mm	Section C Querschnitt C Section C	Length L Länge L Longueur L	Article nr. Artikel Nr. N° Article
			12 x 12 16 x 16	125 125
100BH3-1xxL-6 	Left tool-holder for 6 mm inserts Werkzeughalter links für 6 mm Wendeplatten Porte-outil à gauche pour plaquettes 6 mm	Section C Querschnitt C Section C	Length L Länge L Longueur L	Article nr. Artikel Nr. N° Article
			12 x 12 16 x 16	125 125
100-2 	Screw for tool-holders 100BH3-1xxR-6 and 100BH3-1xxL-6 Schraube für Werkzeughalter 100BH3-1xxR-6 und 100BH3-1xxL-6 Vis pour porte-outils 100BH3-1xxR-6 et 100BH3-1xxL-6			Article nr. Artikel Nr. N° Article
	M3,5 x 9,0			100-2

Profile grinding on brazed tool Formschleifen auf gelöteten Werkzeug Meulage de forme sur burin brasé

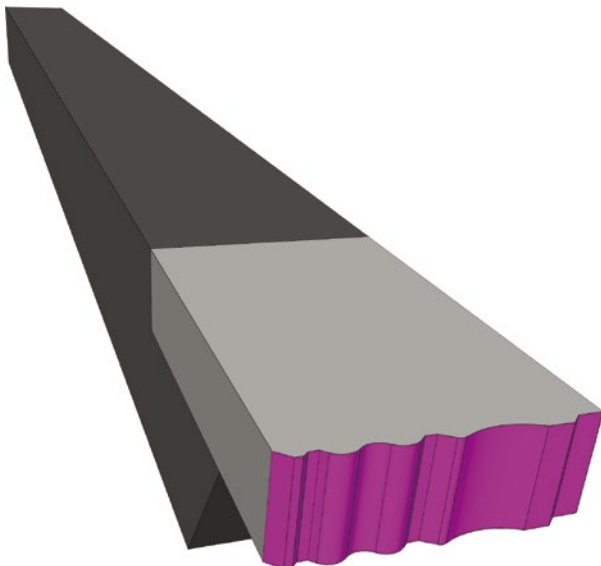

The profile requested by the customer is grinded on the brazed tool.

Brazed tool provided by the client or by Bimu.

Das gewünschte Profil des Kunden wird auf dem gelöteten Werkzeug geschliffen.

Gelötete Werkzeug durch den Kunden oder Bimu bereitgestellt.

Le profil souhaité par le client est meulé sur l'outil brasé.

Outil brasé fourni par Bimu ou par le client.