

Tool-holder type 121 for Tornos Deco 7/10

For small parts parting off. **No need of special collet for pick-up attachment !**

Abstech-Werkzeughalter Typ 121 für Tornos Deco 7/10

Zum Abstechen von kleinen Werkstücken. **Abstechen ohne Abgreifzange mit Vorbau !**

Porte-outil de tronçonnage type 121 pour Tornos Deco 7/10

Pour le tronçonnage de petites pièces. **Pas besoin de pince de prise de pièces à nez prolongé !**

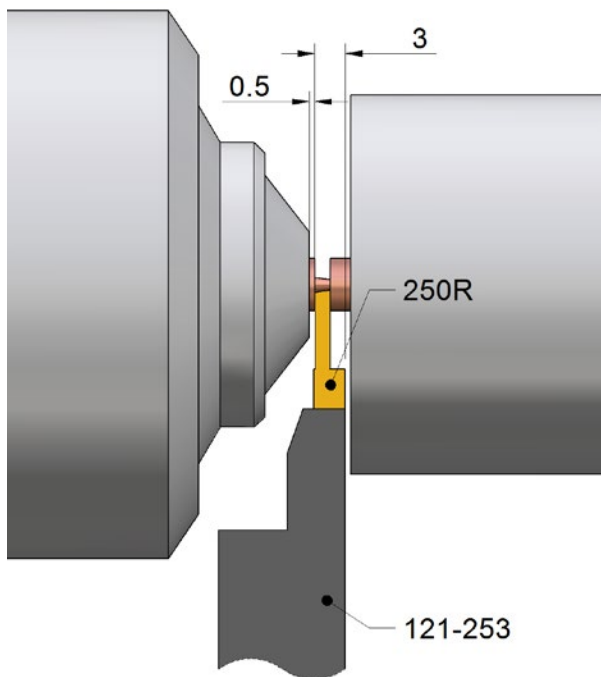

Cutting off guide bush side
Abstechen an der Führungsbüchse
Tronçonnage côté canon

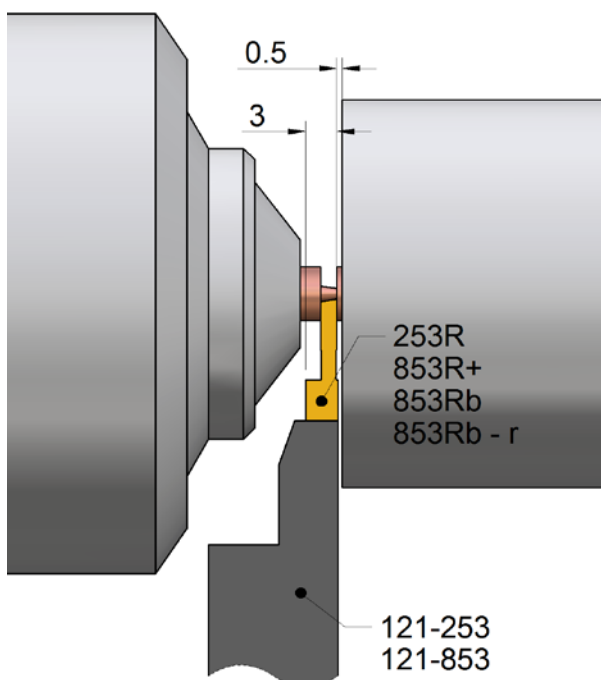

Cutting off counter-spindle side
Abstechen an der Gegenspindel
Tronçonnage côté contre-broche

Tool-holders
Werkzeughalter
Porte-outils

121-253	Description Bezeichnung Description	Article nr. Artikel Nr. N° Article
	<p>Cut-off tool-holder type 121 for inserts 250R and 253R Complete tool (articles 121-1 + 121-2), without insert</p> <p>Abstech-Werkzeughalter Typ 121 für Wendepplatten 250R und 253R Vollständiges Werkzeug (Artikel 121-1 + 121-2), ohne Wendepplatte</p> <p>Porte-outil de tronçonnage type 121 pour plaquettes 250R et 253R Outil complet (articles 121-1 + 121-2), sans plaquette</p>	121-253
	<p>Cut-off tool-holder type 121 for inserts 853R+, 853Rb and 853Rb - r Complete tool (articles 121-1 + 121-3), without insert</p> <p>Abstech-Werkzeughalter Typ 121 für Wendepplatten 853R+, 853Rb und 853Rb - r Vollständiges Werkzeug (Artikel 121-1 + 121-3), ohne Wendepplatte</p> <p>Porte-outil de tronçonnage type 121 pour plaquettes 853R+, 853Rb et 853Rb - r Outil complet (articles 121-1 + 121-3), sans plaquette</p>	121-853
<p>121-x</p>   	<p>Only base plate Nur Basisplatte Uniquement plaque de base</p> <p>Only tool-holder for inserts 250R and 253R Nur Werkzeughalter für Wendepplatten 250R und 253R Uniquement porte-outil pour plaquettes 250R et 253R</p> <p>Only tool-holder for inserts 853R+, 853Rb and 853Rb - r Nur Werkzeughalter für Wendepplatten 853R+, 853Rb und 853Rb - r Uniquement porte-outil pour plaquettes 853R+, 853Rb et 853Rb - r</p>	<p>121-1</p> <p>121-2</p> <p>121-3</p>

Inserts Wendeplatten Plaquettes

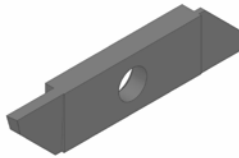
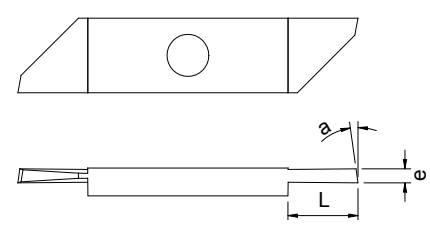
250R	Cutting insert Abstechplatte Tronçonneur	e	L	a	Article nr. Artikel Nr. N° Article	B120	B140	TiN
		1,0	4,5	18°	250R1,0	✓	✓	✓
		1,2	4,5	18°	250R1,2	✓	✓	✓
		1,4	7,5	18°	250R1,4	✓	✓	✓
		1,5	7,5	18°	250R1,5	✓	✓	✓
		1,6	9,5	8°	250R1,6	✓	✓	✓
		1,8	9,5	8°	250R1,8	✓	✓	✓
		2,0	9,5	8°	250R2,0	✓	✓	✓
		2,5	11,0	8°	250R2,5	✓	✓	✓

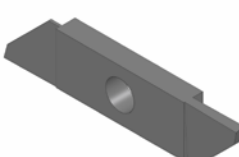
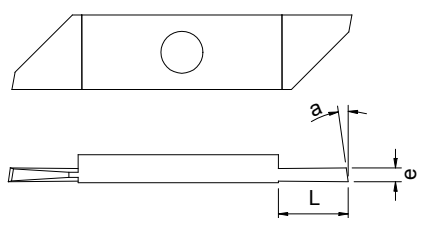
253R	Opposite cutting insert Umgekehrte Abstechplatte Tronçonneur inversé	e	L	a	Article nr. Artikel Nr. N° Article	B120	B140
		1,0	7,5	8°	253R1,0	✓	✓
		1,2	7,5	8°	253R1,2	✓	✓
		1,5	7,5	8°	253R1,5	✓	✓
		1,8	7,5	8°	253R1,8		✓

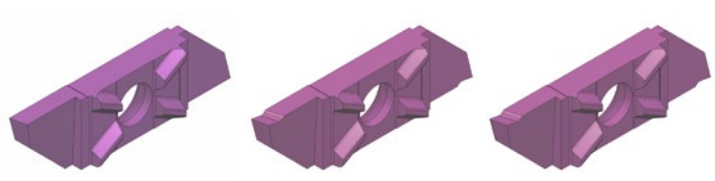
800line+	Different cut off inserts Verschiedene Abstechplatten Différentes plaquettes de tronçonnage
	<p>For further information about 853R+, 853Rb and 853Rb - r inserts, please see the «800line+» catalog.</p> <p>Für mehr Informationen über 853R+, 853Rb und 853Rb - r Wendeplatten, bitte sehen Sie die Katalog «800line+».</p> <p>Pour le détail des plaquettes 853R+, 853Rb et 853Rb - r, voir le catalogue «800line+».</p>

100-2c	Screw M3,5 x 7 Schraube M3,5 x 7 Vis M3,5 x 7	Article nr. Artikel Nr. N° Article
	for / für / pour : 121-2	100-2c

100-4c	Screw M4,5 x 7 Schraube M4,5 x 7 Vis M4,5 x 7	Article nr. Artikel Nr. N° Article
	for / für / pour : 121-3	100-4c

