

ISO line

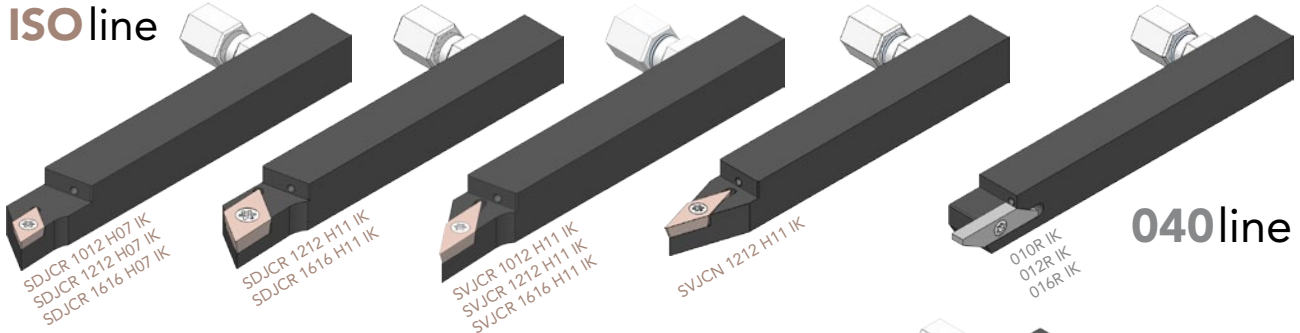

040line

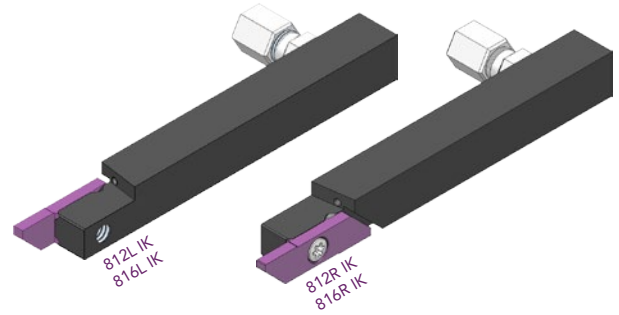

oxoline

Very high rigidity inserts 1000

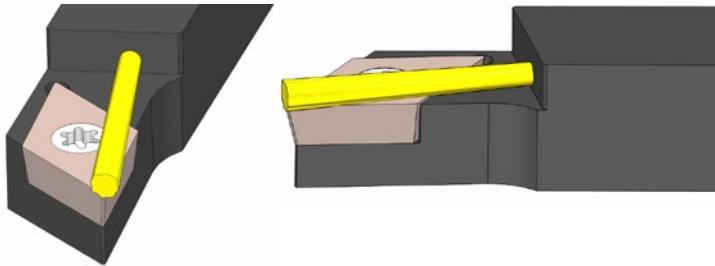
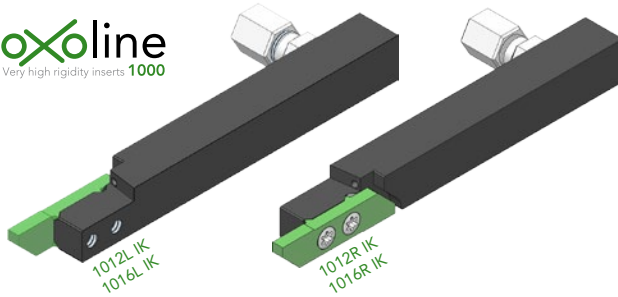

- High pressure coolant directly on the cutting edge. Coolant in the insert's axis.
- Durch Hochdruckkühlung entlang der Längsachse, direkt auf die Schneidkante der Wendeplatte, erhalten Sie eine deutlich bessere Oberflächengüte und erheblich längere Standzeiten Ihrer Werkzeuge.
- Arrosage haute pression sur l'arête de coupe. Jet dans l'axe de la plaquette.

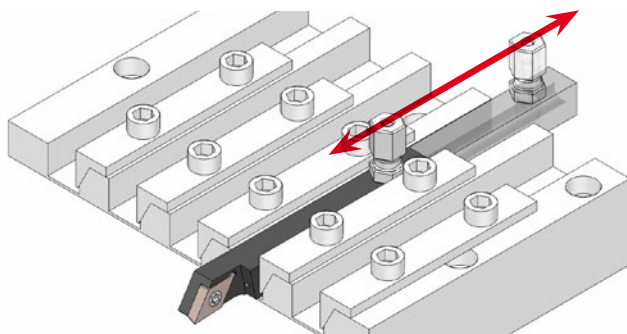

- Possibility to slide the tool-holder on whole length for setting.
- Beim Einrichten können diese Werkzeughalter in ihrer gesamten Länge auf dem Träger gleiten.
- Possibilité de coulisser l'outil sur toute la longueur pour le réglage.

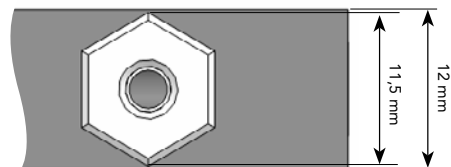
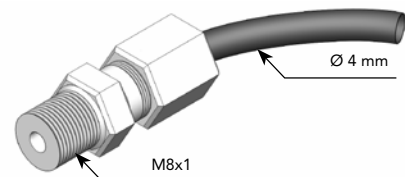

- The hydraulic fitting does not cover the tool, even for section 12x12 mm.
- Das hydraulische Anschlussstück ragt nicht über die Breite des Halters hinaus, auch nicht bei Querschnitten 12x12 mm.
- Le raccord hydraulique ne dépasse pas de l'outil même en section 12x12 mm.



1 hydraulic fitting (M8x1, cone shape, output Ø 4 mm) is delivered with each tool-holder.
1 hydraulischer Anschluss (M8x1, konisch, Ausgang Ø 4 mm) wird mit jedem Werkzeughalter geliefert.
1 raccord hydraulique (M8x1 conique, sortie Ø 4 mm) est livré avec chaque porte-outil.

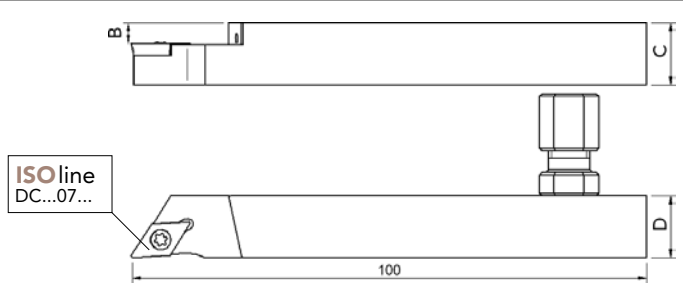
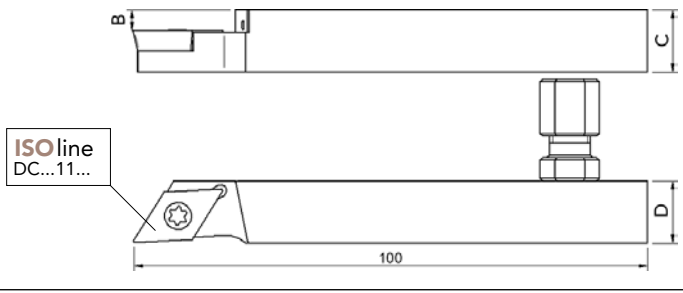
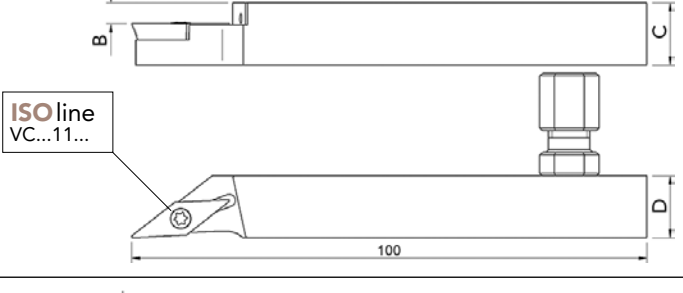
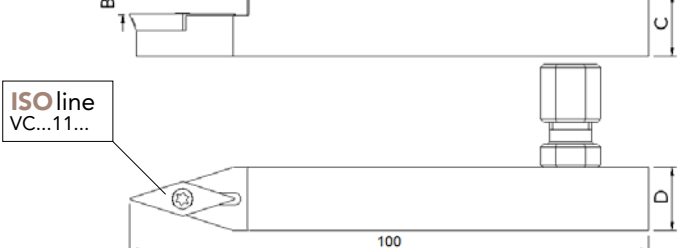

To guarantee the smooth running of tool-holders, the oil must be filtered in 60 µm.
Um einen reibungslosen Ablauf der Werkzeughalter zu gewährleisten, muss das Öl in 60 µm filtriert werden.
Afin de garantir le bon fonctionnement des porte-outils, l'huile doit être filtrée à 60 µm.

Tool-holders with internal coolant Werkzeughalter mit Innenkühlung Porte-outils avec arrosage	CxD CxD CxD	B B B	Article nr. Artikel Nr. N° Article
 <p>ISO line DC...07...</p>	10x12 mm	3	SDJCR 1012 H07 IK
	12x12 mm	4	SDJCR 1212 H07 IK
	16x16 mm	4	SDJCR 1616 H07 IK
 <p>ISO line DC...11...</p>	12x12 mm	4	SDJCR 1212 H11 IK
	16x16 mm	4	SDJCR 1616 H11 IK
 <p>ISO line VC...11...</p>	10x12 mm	3	SVJCR 1012 H11 IK
	12x12 mm	4	SVJCR 1212 H11 IK
	16x16 mm	4	SVJCR 1616 H11 IK
 <p>ISO line VC...11...</p>	12x12 mm	4	SVJCN 1212 H11 IK

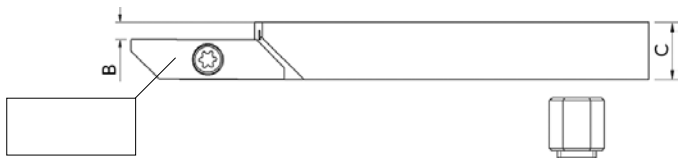
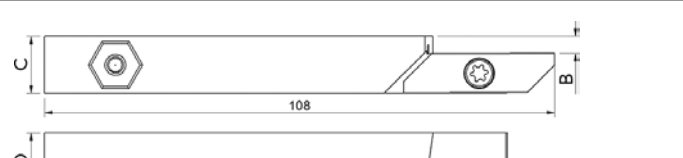
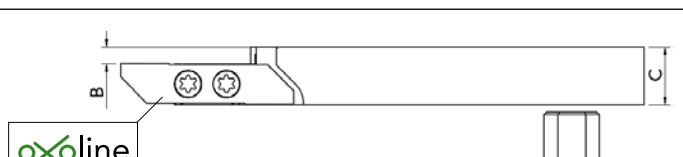
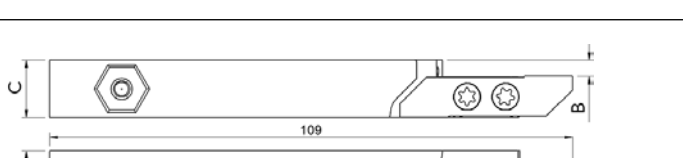
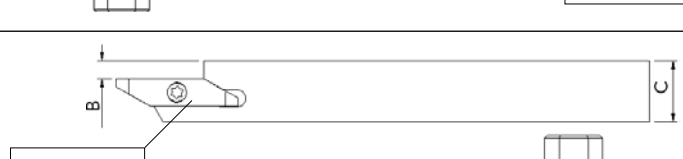
Tool-holders with internal coolant Werkzeughalter mit Innenkühlung Porte-outils avec arrosage	CxD CxD CxD	B B B	Article nr. Artikel Nr. N° Article
	12x12 mm	3,6	812R IK
	16x16 mm	3,6	816R IK
	12x12 mm	3,6	812L IK
	16x16 mm	3,6	816L IK
	12x12 mm	3,4	1012R IK
	16x16 mm	3,4	1016R IK
	12x12 mm	3,4	1012L IK
	16x16 mm	3,4	1016L IK
	10x12 mm	2,5	010R IK
	12x12 mm	3,5	012R IK
	16x16 mm	3,5	016R IK

Replacement screw for tool-holder... Ersatzschraube für Werkzeughalter... Vis de remplacement pour porte-outil...	Description Bezeichnung Description	Article nr. Artikel Nr. N° Article
SDJCR 1012 H07 IK	M2,5 x 7,5	001-7
SDJCR 1212 H07 IK		
SDJCR 1616 H07 IK		
SDJCR 1212 H11 IK	M3,5 x 7	100-2c
SDJCR 1616 H11 IK	M3,5 x 9	100-2
SVJCR 1012 H11 IK	M2,5 x 7,5	001-7
SVJCR 1212 H11 IK		
SVJCR 1616 H11 IK		
SVJCN 1212 H11 IK		
812R IK	M4,5 x 10,5	100-4
816R IK		
812L IK		
816L IK		
1012R IK	M3,5 x 9	001-8
1016R IK		
1012L IK		
1016L IK		
010R IK	M2,5 x 7,5	001-2
012R IK		
016R IK		